

Bird & Bird

# Report of Trade Mark Cases

For the CIPA Journal

*January 2025*



# Trade mark decisions

## easyGroup loses another case

*EasyGroup Ltd v Easyfundraising Ltd ("EFL") & Ors* (Fancourt J; [2024] EWHC 2323 (Ch) and [2024] EWHC 3210 (Ch); 11 September and 21 November 2024)

In the December 2024 issue of *The CIPA Journal*, we reported on *easyGroup v Beauty Perfectionist* [2024] EWHC 2282 (Ch) and *easyGroup v Easy Live* [2024] EWHC 1441 (Ch). Shortly after those decisions, a further decision was handed down and, again, *easyGroup* were unsuccessful, this time in stopping the use of a sign and logos incorporating the word *easyfundraising*. Costs were awarded to EFL on an indemnity basis. Katharine Stephens reports.

### Revocation actions

The Judge first decided the counterclaims for revocation for non-use in relation to certain of *easyGroup*'s marks. Two of the marks had previously been considered by the High Court.

The counterclaim for revocation in relation to the *easyJet* mark succeeded in part to the extent that a fair specification of the class 35 services was restricted to retail services for airline passengers. There had been no use on retail services elsewhere or by other means. In so finding, the Judge agreed with the reasoning of Bacon J in the *Beauty Perfectionists* case.

The Judge also revoked, this time wholly, a figurative mark for *easylife* (shown below) registered in class 35. It had not been used in the form in which it was registered, but in the different variants shown in the table which the Judge held altered the distinctive character of the mark.



A The Tickball Variant	The logo features a blue tickball icon to the left of the word 'easylife' in a blue, lowercase, sans-serif font.
B The Tickball Everyday Variant	The logo features a blue tickball icon to the left of the word 'easylife' in a blue, lowercase, sans-serif font, with 'everyday solutions' in a smaller, blue, lowercase, sans-serif font below it.
C The Tickball Lifestyle Variant	The logo features a black tickball icon to the left of the word 'easylife' in a black, lowercase, sans-serif font, with 'lifestyle solutions' in a smaller, black, lowercase, sans-serif font below it.
D The Text Variant	EASYLIFE
E The Text Lifestyle Variant	EASYLIFE LIFESTYLE SOLUTIONS

After the Judge sent his judgment to the parties in draft form, he was provided with a copy of the judgment in the *Easy Live* case which was subsequently handed down. In that case, the defendant had asserted that the *easylife* mark should be revoked for non-use, but the Judge, Mr Caddick KC, concluded that the claim failed because, in his judgment, the variants were variant forms of the registered mark within section 46(2).

Fancourt J considered but was not persuaded to follow Mr Caddick's decision. It was not the words "easylife" alone that made the mark distinctive. Accordingly, the lack or change of the other distinctive elements altered the distinctive character of the mark. Each of the Tickball Variants created visually a different overall impression from the registered mark and since the visual appreciation of them would be the most prevalent form, they had, overall, a different distinctive character.

Finally, the Judge revoked the *easy.com* mark registered in class 38 for "electronic mail services". It had not been used in relation to the selling or promotion of electronic mail services. Instead, @*easy.com* email addresses had been given away for free so that customers could see what other *easy+* brands were available. Therefore, there was no use of the requisite quality to amount to genuine use.

## Infringement under Section 10(2)

### 2005 and 2007 signs

The Judge first considered EFL's early uses of the sign "easyfundraising" which EFL started using in plain text and in the following format from 2005:

**easyfundraising**

From 2007, EFL also used "easysearch" in connection with an online search engine and in the following format:

**easysearch**

Following the Judge's decisions in relation to the counterclaims for revocation, the Claimant's infringement case under section 10(2) was based on the following three marks:

- EASYJET registered in class 39 broadly for transport, vacations, travel and tourism;
- easyHotel / EASYHOTEL registered in class 42 for hotel services, providing hotel accommodation and reservation services for hotel accommodation; and



- **easyGroup** registered in class 35 for commercial administration and management of the licensing of good or services.

As to the similarity of the marks and the sign easyfundraising (both the logo and the plain word sign), the average consumer would perceive them as having some degree of similarity, but not strongly so. Further, the word "easy" would not be perceived as a dominant characteristic of the marks. As to the easysearch sign, the same conclusion applied.

As to the services, the easyfundraising website was used by people, called "supporters", wanting to raise money for their chosen charity or good cause through making purchases online with their chosen retailer. The Judge found that an average supporter would have understood that easyfundraising was not selling the services or goods that they clicked through the platform to purchase from the retailer. The experience of using the platform created, and was intended to create, distance between easyfundraising and the retailer, whatever sales jargon was used e.g. "partners", "we offer" and the like. EFL had not presented itself as a partner of retailers selling travel, holiday or hotel services nor was it responsible for the delivery or quality of such services sold by the retailer. Therefore, there was no similarity between EFL's services and those in respect of which easyJet and easyHotel were registered (and no such case was made in relation to easysearch). Further, there was no similarity with the services specified for the easyGroup mark.

Given that conclusion, the case on infringement as at 2005 and 2007 failed.

### 2009 sign

From 2009, EFL used the handle @easyuk on social media. The claim to infringement related to the same three marks set out above. The Judge noted that there was a closer degree of similarity between this sign and the marks than in relation to easysearch and easyfundraising. However, there was no infringement because there was no similarity of services.

### 2015

In 2015, EFL changed its trading sign to:



easyGroup's case was that this sign infringed the above mentioned three marks in addition to the following:

**EASY**

- **NETWORKS** registered in class 38 for internet access services and ISP services; and
- EASYJET in class 35 for various retail services (which the Judge had held should be restricted to retail services for airline passengers).

The Judge held that there was less similarity between the easyJet, easyHotel and easyGroup marks and the 2015 sign than there was between those marks and EFL's earlier signs. As to the Easy Networks mark, there was some similarity, albeit low.

Since EFL's business model had not changed by 2015, the Judge's conclusion on the similarity, or rather dissimilarity, of services remained as before. He also examined and concluded that the eight instances of alleged confusion did not prove actual confusion (direct or indirect) by an average consumer.

#### 2022 sign

In 2022 EFL changed its trading sign again to:



The Judge did not accept that EFL had, in redesigning its sign, moved closer to the easy+ marks and held that the yellow-gold logo was dissimilar to the orange background in the easyGroup mark and as used by easyJet and easyHotel. There was therefore only a low level of similarity. However, as before, the Judge concluded that there was no similarity of services.

In addition to the marks claimed to be infringed by the 2015 sign, the infringement case made against the 2022 sign included an easylife mark registered in 2020 by easyGroup following acquisition of the brand from Easylife Ltd. It was registered in class 35 for advertising and marketing services, retail services, online retailing and mail order.

There was a low level of similarity between the 2022 sign and the easylife mark. There was also a low level of similarity between the word signs easyfundraising and easysearch and easylife; the similarity was limited to the word "easy" which was not strongly distinctive.

As to services, the Defendants accepted that EFL's advertising and marketing services were identical to services for which easylife was registered in 2020. The average consumer of these services was professional, sophisticated and careful and would have been aware of the nature of the business operation of EFL. However, the Judge held that there was no risk of that they would have been confused into thinking that easyfundraising was one of the easy+ companies or associated with them.

In relation to online retail services for which easylife was also registered, the Judge held that there was some similarity, but only at a fairly high level. Importantly, EFL provided a portal that a supporter could use to pass through (for a particular purpose) to buy products from other retailers whereas Easylife provided a website from which various products, including ones made by third parties, could be purchased directly from it.

Despite some similarity in retail services, the Judge held that there was no risk of confusion. Any user of the easyfundraising or easysearch site would be there for a specific reason, which only those sites provided. The Judge noted that at the relevant date, Easylife advertised on easyfundraisings's platform, so it was evident that Easylife was something different. As to indirect confusion, the presence of the word "easy" was insufficient to lead an average consumer to think there was a connection or that easyfundraising was another easy+ brand or connected to the brands.

## *Infringement under Section 10(3)*

### *2005 and 2007 signs*

The Defendants conceded that easyJet had reputation for airline services. The Judge held that easyHotel and easyGroup did not have a reputation at the relevant dates. In addition to these three marks used as the basis for the section 10(2) claim, the Claimant also pleaded infringement of easyMoney registered in class 36 for financial services in the following formats:



easyMoney only struggled over the reputation line in 2007 in relation to loans and mortgages.

The Judge held that, in 2005, there was a family of easy+ brands, but it was identifiable by the use of the Cooper Black font and the white and orange colours and was therefore distinguishable from other businesses using the word "easy" as part of their names.

The Judge held that there was no link between EFL's signs and the easy+ marks given the large number of other businesses using the prefix "easy" and the fact that the consumer's use of easyfundraising and easysearch was wholly different to the services provided by easyJet and easyMoney. Everything other than the presence of the prefix "easy" was so different, and "easy" was just a descriptive word that many businesses used as part of their names.

### *2009 sign*

By 2009, easyHotel had a reputation as did easyGroup for their respective services but this made little difference to the Judge's analysis which was much the same as set out above.

### *2015 sign*

In addition to the four marks pleaded in relation to the 2005, 2007 and 2009 uses, the Claimant pleaded infringement of the Easy Networks mark and the easyJet mark registered in class 35.

By 2015, easyMoney had a reputation in relation to all the specified services, easyGroup had a reputation amongst its licensees, Easy Networks had been trading since 1995 and had a reputation among business users of internet access and IPS services, but would not have been seen as one of the easy+ brands. easyJet had a very extensive reputation, but its reputation for retail services related specifically to airline passengers.

The Judge again noted the importance of the Cooper Black font and the orange and white livery to the existence of the easy+ family of brands. In balancing the fame of easyJet, supported to some extent by the family of brands, he found there was no link with easyfundraising. The context of the use of the latter was very different and it was a very different sign. The use of the word "easy" as the first part of a name remained essentially descriptive and was used by a large number of other businesses, some of which, such as Easylife, were also household names by this time.

### *2022*

The claim for infringement in 2022 additionally pleaded the easylife registration in class 35. In relation to all the marks bar the easylife mark, the Judge reached the same conclusion as he did in relation to the 2015 sign.

By 2022, Easylife had a reputation for advertising and marketing services amongst its professional customers and it was admitted to have a reputation for its online and mail order retail services. However, it would not have been seen as one of the easy+ brands.

The supporters of easyfundraising who used its platform to support good causes while buying goods and services from the thousands of retailers listed there, were also likely to have been users of other online retail opportunities. By 2022, these were on an almost unlimited scale and they included online services provided by Easylife. As already noted, Easylife was an advertiser on easyfundraising until its brand was acquired by easyGroup in 2022.

The Judge had already held that the use of the prefix "easy" would be insufficient to create a link where the goods or services were dissimilar. However, in relation to the easylife mark, there were at least some high-

level similarity in online retail services facilitated (but not provided) by easyfundraising (but not by easysearch). Therefore, a significant proportion of average consumers would probably make a link between the marks. This link stopped well short of confusion and hence the passing off case failed. (It was agreed that all the other passing off claims would follow the determination of the outcome of the claims under section 10(2)).

The Claimant had no viable case of unfair advantage or damage to reputation or distinctive character in relation to any of the marks. In relation to the former, there was no evidence that EFL had obtained an advantage, let alone an unfair one, by using the word "easy" other than to communicate the ease with which supporters could provide benefits to good causes. Given the number of traders over the years using the word "easy", the Claimant could not prove an insidious transfer of image. The Claimant did not have a monopoly over the word "easy" which was the effect of the Claimant's closing submissions contending that EFL obtained an unfair advantage because they did not pay a licence fee to use their name.

There was no evidence of any damage caused or likely to be caused and the use by EFL of its signs did nothing to harm the distinctiveness of the marks even if, as the Judge refused to accept, the easy+ brands had been so well known that "easy-anything" would have called them to mind. As the Judge pointed out, had the Claimant been concerned that it was suffering damage, it would not have allowed 10 years to elapse between sending the first letter before action in 2011 and issuing proceedings.

### Costs

The Judge awarded the Defendants costs on an indemnity basis. The Claimant's pre-action conduct (including the long periods of silence between negotiations and then finally issuing proceedings without warning) in addition to other factors (including pursuing a weak case in an unreasonable way) combined to persuade the Judge to make this somewhat unusual order.

## Low distinctiveness leads to non-infringement finding

*Shorts International Ltd ("SIL") v Google LLC (Michael Tappin KC, sitting as a Deputy High Court Judge; [2024] EWHC 2738 (Ch); 31 October 2024)*

*The High Court rejected a trade mark infringement and passing off claim against certain signs relating to the 'YouTube Shorts' service. The Court found, inter alia, that all of the trade marks asserted had low inherent distinctive character, that only some uses of the word "shorts" indicated origin, that there was no likelihood of confusion or damage to distinctive character or repute, and no misrepresentation for passing off purposes. Naji Tilley reports.*

### Facts

SIL is the owner and operator of ShortsTV, a worldwide television network dedicated to short films. Google is the owner of the well-known online video sharing platform, YouTube.

SIL owned various UK trade mark registrations in classes 9 (for, amongst other things, sound, video and data recordings, cinematographic films; films for television), 38 (for, amongst other things, broadcasting and transmission of films, television programmes) and 41 (for, amongst other things, entertainment services). The first two marks (the "ShortsTV Marks") and the second two mark (the "Shorts Marks") (together the "Figurative Marks") are shown below. SIL also owned a word mark for SHORTSTV (the "Word Mark").

SHORTSTV

SHORTSTV

SHORTS

SHORTS

In June 2021, Google launched the YouTube Shorts service in the UK. This service was available on the YouTube website and focused on videos of less than 60 seconds, in vertical format.

The YouTube Shorts logo was represented in various formats, including:

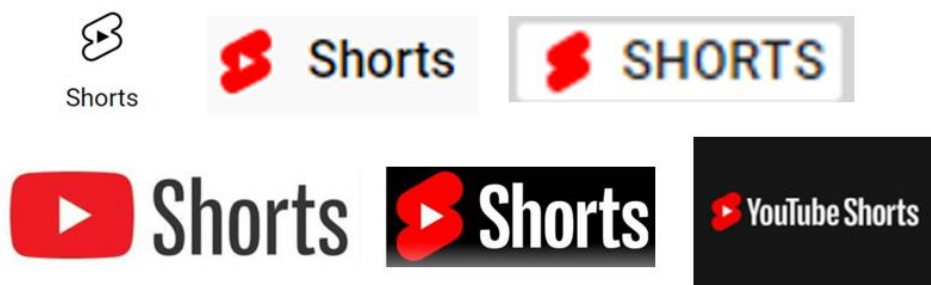

SIL claimed that Google's use of the words "Shorts" and "YouTube Shorts", as well as the YouTube Shorts logos, infringed the Marks under section 10(2) and (3) and amounted to passing off.

### Invalidity under section 3(1)(b)-(d)

Firstly, the Judge considered Google's counterclaims that the Marks were invalid.

He held that the Shorts Marks were not descriptive under section 3(1)(c). He found that, during the relevant period, the word "shorts" had been used to refer to short-form audiovisual content and included, but was not limited to, "short films". Therefore, while individually the word "shorts" and the red triangle (which represented a play symbol to the average consumer) designated characteristics of the goods, the combination of the two meant that the mark did not consist "exclusively" of indications designating those characteristics. Although SIL's position on the ShortsTV Marks could not be worse, the Judge concluded that it was no better than SIL's position on the Shorts Marks for reasons set out in relation to the Word Mark.

The Judge held that the Word Mark did not create an impression sufficiently beyond that produced by simply combining "shorts" and "TV". On the contrary, combining the words gave the simple impression that the goods were shorts provided by televisual means, and that the services involved the provision of shorts by televisual means. The Judge concluded that for most, but not all, of the specified goods and services, the Word Mark was invalid under section 3(1)(c).

As for invalidity under sections 3(1)(b) and (d), the Judge reached the same conclusions. He found the Word Mark invalid to the same extent as under section 3(1)(c). The Figurative Marks were not vulnerable. The inherent distinctive character of each of the Marks was low (and in relation to the Word Mark, only for some of the goods and services for which it was registered). None of the Marks had acquired distinctiveness through use or had an enhanced distinctive character.

### Revocation for non-use

In relation to the Figurative Marks, SIL conceded non-use with the exception of "electronic entertainment software" and "computer software" in class 9 and "entertainment services" in class 41. It was also between the parties that use of one form of the Shorts Marks was use of the other and vice versa. Similarly, with the ShortsTV Marks. It was also agreed that use of the ShortsTV Marks counted as use of the Shorts Marks, but not vice versa.

The first issue for the Judge was whether a variant sign, "SHORTSTV+", used in relation to the ShortsTV+ mobile app, altered the distinctiveness of the ShortsTV Marks. He held it did not as the additional '+' symbol did not add anything significantly distinctive.

The Judge then had to consider whether SIL's use of "SHORTSTV+" in relation to the app counted as use for the remaining class 9 goods. While the app itself was a form of both, of "electronic entertainment software" and "computer software" was not a fair specification when considering the purpose and intended use of goods in issue. The Judge concluded that the specification should be replaced with "software for accessing audiovisual entertainment".

The Judge also found that, while there was genuine use of the Figurative Marks for various services falling under "entertainment services" in class 41, the specification was too wide, and should be limited to "production,

presentation and distribution of films, videos and television programmes". Therefore, the Figurative Marks were partially revoked for non-use.

### Infringement under section 10(2)

The Judge began by considering how to identify the sign being used, for the purposes of assessing the similarity and the likelihood of confusion. He considered that the Court was required to consider each use of the sign, bearing in mind the context in which consumers would see it, but was not permitted to take into account matters not visible to the consumer when the sign was being used.

The Judge found that Google's use of the word "Shorts" in isolation, on certain pages on the YouTube website or mobile app, constituted use in a purely descriptive sense. By contrast, when "Shorts" was used as part of the word sign or figurative sign for "YouTube Shorts", either in combination with the full YouTube logo or a derivative logo without the word "YouTube", the average consumer would see that use both as descriptive and as part of a composite sign indicating origin.

The marks were visually, aurally and conceptually similar, but there were also differences. For the Figurative Marks, the Judge held that, the similarities were at a level which differed from that which gave them their distinctive character. Even if the Word Mark had been valid across the whole of its specification its distinctive character would arise from the combination of "shorts" and "TV", which was absent from all of Google's signs.

Google conceded that it had used its signs on goods and services which were identical to certain of those for which the Figurative Marks were registered. The same could be said for the Word Mark (absent the Judge's findings on invalidity).

Despite the identity of the goods/services, the Judge held that even on SIL's best case (comparing the Shorts Marks with the first of Google's composite signs shown above) there was no likelihood of confusion. Both the Marks and the sign contained the word "shorts" and the play symbol, but the former was descriptive of the material in question and the play symbol indicated that the material could be played. In relation to the other Marks and Signs, there were additional elements pointing away from a likelihood of confusion.

The Judge concluded that the average consumer would not mistake any of the signs for any of the Marks, or believe that the origin of the goods and services was the same or an economically linked undertaking. There was also a lack of evidence of actual confusion by consumers representing the "average consumer".

### Infringement under section 10(3)

The Judge noted that SIL's Marks were not known by a significant part of the public concerned by any of the categories of goods or services for which the Marks were registered. However, he noted that while it was possible to rely on a reputation for a narrower category of goods than the ones mentioned in the specification, this had to be an identifiable sub-category of goods of a size comparable to the category for which the mark was registered. He did not regard "short films" as a proper sub-category of goods and therefore SIL did not have a reputation in the UK for the purposes of section 10(3). (SIL had claimed that "short films" and "shorts" were distinguishable from feature films in their length (up to 45 minutes), but distinguishable from short videos on YouTube Shorts by their content's quality, such as narrative, storyline, composition, acting, framing, lighting, camerawork and editing, but the Judge rejected these subjective elements as a basis for identifying a sub-category of goods, as opposed to the good's characteristics.)

Even if "short films" could be seen as a proper sub-category, and even if Google's use of its composite signs had created a "link" between a sign and any of the Marks, there was no dilution. The (low) distinctive character of the word "shorts" in combination with a play symbol, was not sufficiently affected by Google's activities. This was the case, even if those activities had the effect of increasing the use of the word "shorts" for one type of short-form audiovisual content and changing the weight of usage of the word "short films".

On tarnishing, the Judge rejected SIL's argument that its Marks or services, being "short films", were likely to be cheapened by an association with the type and quality of material available on YouTube Shorts. Google's activities had not caused detriment to the Marks, as opposed to "short films" as an art form. The Judge had already concluded that "shorts" did not exclusively mean "short films" and the fact that the centre of gravity of the use of the word "shorts" had moved away from "short films", did not mean the repute of the Marks had suffered.



### The "honest practices" defence in section 11(2)(b)

While this was not necessary to decide, the Judge concluded that the defence would have failed.

Google's use of the word "Shorts" alone was the use of a sign which in itself was not distinctive and concerned the kind (or other characteristics) of goods and services. However, the Judge drew an adverse inference that Google knew of the existence of the Marks at the time it decided to name the YouTube Shorts service. Moreover, Google knew that SIL had complained about its use of "Shorts" around one month after the name was decided upon, and nine months before YouTube Shorts was launched in the UK.

Overall, in proceeding with YouTube Shorts in the UK with that knowledge, Google took the risk that SIL's allegations would prove to be correct – and if they had, Google would not have been acting fairly with regard to SIL's legitimate interests.

### Passing off

SIL's passing off claim also failed. At the relevant time, SIL had protectable goodwill in the UK associated with the Marks (save for the word "shorts" alone), principally among filmmakers.

However, Google's use of "shorts" did not amount to a misrepresentation or thereby cause damage to SIL's goodwill. Given that YouTube was a renowned and long-established brand, it was not likely that a substantial amount of the public would be misled that YouTube Shorts came from the same origin as that of the Marks or was otherwise authorised by SIL.

## Exhaustion defence rejected due to impression of commercial connection

### AGA Rangemaster v UK Innovations Group Ltd & Anor (Nicholas Caddick KC, sitting as a Deputy High Court Judge; [2024] EWHC 1727 (IPEC); 8 July 2024)

*The High Court found that UK Innovations' use of AGA's marks in relation to retrofitted AGA cookers constituted trade mark infringement. UK Innovations did not have a defence under sections 11 or 12. Lauren Ensign reports.*



### Background

AGA is the manufacturer of the well-known line of AGA range cookers. The first defendant, UK Innovations, manufactures range cookers fitted with an electric control system; the "eControl System".

The eControl System can be fitted to traditional AGA cookers to convert them from gas to electric power. UK Innovations had sold a total of 26 AGA cookers fitted with the eControl System (the "eControl Cookers"). These eControl Cookers retained the appearance of the original AGA cookers, including the "AGA" badge, save for an "eControl System" badge which replaced the temperature gauge from the original cooker. AGA objected to UK Innovation's actions.

### Infringement

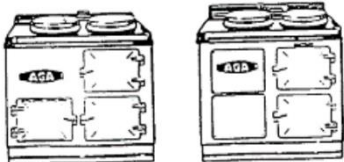
AGA relied on their registrations for the word mark AGA, as well as the figurative mark for its badge (the "Figurative Mark"), the 2D mark (the "2D AGA Mark") and 3D mark (the "3D AGA Mark") (together the "AGA Marks") detailed in the table below:

Figurative Mark	2D AGA Mark	3D AGA Mark
		

Save in respect of the 2D AGA Mark (and had it been pleaded, the 3D AGA Mark), UK Innovations accepted that their actions fell within section 10(1) and (2). They disputed there was infringement under section 10(3) and relied on the defence of sections 12, 11(2)(b) and (c) and counterclaimed seeking to invalidate the 2D AGA Mark and 3D AGA Mark.

### Exhaustion defence

The Judge's decision as to whether the section 12 defence applied hinged on whether AGA had legitimate reasons to object to further dealing of the original AGA cookers, notwithstanding the fact their rights had been exhausted on the basis that the eControl Cookers were AGA cookers that had previously been placed on the market by AGA with their consent.

The Judge found that AGA did not have legitimate reasons to object to further dealings on account of the refurbishment and conversion works. These works, although significant, were not sufficient in the absence of evidence of a risk of serious harm to the reputation of the marks.

The fact that some of the parts used to refurbish the cookers were arguably of a lesser quality did not give rise to legitimate reasons. Consumers would expect second-hand refurbished goods to contain replacement parts which might not be of equal quality to original parts and they would not necessarily associate any quality issues with AGA.

The Judge also rejected AGA's argument that the presence of the "eControl System" badge on the eControl Cooker gave rise to a risk of post-sale confusion as:

- i. consumers would likely view the badge as descriptive; and
- ii. given the longevity of AGA cookers and the inevitable servicing/refurbishment which would take place, it is not unreasonable for third parties who had undertaken the work to place a mark on the goods.

However, the Judge found that AGA did have legitimate reasons to object due to the way in which the eControl Cookers were sold and marketed. Customers were likely to believe there was a commercial connection between the eControl Cookers and AGA because of statements on UK Innovations' website which gave the impression they were being offered an AGA product i.e. an eControl AGA, one of a range of AGA products. This was regardless of the higher level of attention that would be paid by consumers given the price of the goods and the protracted process of purchasing.

### Section 11 defence

UK Innovations used phrases such as "eControl AGA", "AGA Cooker eControl" or "Controllable Aga Cookers" on its website and invoices. It argued AGA was used to explain the purpose of their products.

However, the Judge held that this use of the AGA Marks was neither descriptive nor referential but rather was use as part of a figure of origin. The use suggested that the eControl Cookers and the eControl System were associated with the Claimant as the proprietor of the AGA Word Marks. UK Innovations' use was not in accordance with honest practices, as required for the defence to apply, as the goods in question had been significantly altered.

### Section 10 issues

The Judge rejected UK Innovations' argument that the 2D AGA Mark had not been infringed on the basis that it had not used these marks as trade marks per se by using images of, and dealing with, the physical embodiment of the marks. An image could clearly be a sign and had been used as such.

The Judge held that liability was not excluded by the disclaimer that attached to the 2D AGA mark: "Registration of this mark shall give no right to the exclusive use of the device of a cooker". The average consumer would understand this disclaimer as meaning that the registration gave the proprietor an exclusive right in relation to the device of the particular cooker depicted but not in relation to the device of a cooker generally.

Further UK Innovations' activities were constituted infringement under section 10(3) as they were detrimental to and took unfair advantage of the distinctive character of the AGA marks and were without due cause.

### Joint tortfeasance

The second defendant, Michael McGinley, was the director and person in day-to-day control of UK Innovations. The Judge rejected AGA's claim that he was a joint tortfeasor.

While Mr McGinley had some of the necessary requisite knowledge, there were numerous vital facts which had not been shown to have been known to Mr McGinley. It could not be found that he knew UK Innovations' activities were liable to affect the origin function of AGA's marks, give rise to a likelihood of confusion, or were detrimental to their reputation or distinctive character.

### Invalidity

The Judge rejected UK Innovations' argument that the 2D AGA Mark did not satisfy the definition in section 1(1) due to a lack of certainty as to its nature. The Judge held that the average consumer looking at the mark would take it for exactly what it was - a 2D representation of a 3D object.

As to the 3D AGA Mark, the Judge found it was also not uncertain. The visual representation of the mark was not inconsistent with the verbal representation as had been argued. It also complied with section 3(2) - the shape of its essential characteristics could not be said to be exclusively the result of the fact that the thing depicted is a cooker, neither were its features necessary to obtain a technical result.

*All decisions are to be found on <https://www.bailii.org>*



*Katharine Stephens*

Partner

+442074156104  
*katharine.stephens@twobirds.com*



*Nick Cowen*

Associate

+442078507293  
*nick.cowen@twobirds.com*

## Reporters

Katharine Stephens; Naji Tilley; Lauren Ensign

*This report was first published in the CIPA Journal, January 2025*

twobirds.com

Abu Dhabi • Amsterdam • Beijing • Bratislava • Brussels • Budapest • Casablanca • Copenhagen • Dubai  
• Dublin • Dusseldorf • Frankfurt • The Hague • Hamburg • Helsinki • Hong Kong • London • Lyon  
• Madrid • Milan • Munich • Paris • Prague • Rome • San Francisco • Shanghai • Shenzhen • Singapore  
• Stockholm • Sydney • Tokyo • Warsaw

The information given in this document concerning technical legal or professional subject matter is for guidance only and does not constitute legal or professional advice. Always consult a suitably qualified lawyer on any specific legal problem or matter. Bird & Bird assumes no responsibility for such information contained in this document and disclaims all liability in respect of such information.

This document is confidential. Bird & Bird is, unless otherwise stated, the owner of copyright of this document and its contents. No part of this document may be published, distributed, extracted, re-utilised, or reproduced in any material form.

Bird & Bird is an international legal practice comprising Bird & Bird LLP and its affiliated and associated businesses.

Bird & Bird LLP is a limited liability partnership, registered in England and Wales with registered number OC340318 and is authorised and regulated by the Solicitors Regulation Authority (SRA) with SRA ID497264. Its registered office and principal place of business is at 12 New Fetter Lane, London EC4A 1JP. A list of members of Bird & Bird LLP and of any non-members who are designated as partners, and of their respective professional qualifications, is open to inspection at that address.